



PLS Battery Co., Ltd

Ver:

A

DATE:

2017-11-20

DOC No:

PLS-ICR21700-4000

CUSTOMER NO: _____

Specification Approval Sheet

MODEL: 21700

(4000mAh 3.7V)

Prepared By/Date	Checked By/Date	Approved By/Date

Customer Name:

Comment:

Customer Approval /Date:

Address: 2nd Floor, No. 4, Hebe Road, Tangxia Town, Dongguan City, Guangdong Province

Tell: +86 13480631900, +86 17704074080

Email: sales@plsbattery.com

Website: www.plsbattery.com



Amendment Records

Revision	Description	Prepared by	Approved by	Date
A	First Publish			



Content

2. Model	Page 4
3. Cell Specification	Page 4
4. Battery/Cell performance test Criteria	Page 5
4.1 Appearance inspection by visual	Page 5
4.2 Environmental test condition	Page 5
4.3 Electrical characteristics	Page 5
4.4 Mechanical characteristics	Page 6
4.5 Safety performance	Page 7
5. Cell initial Dimensions	Page 8
6. CAUTIONS IN USE	Page 9
7. Period of Warranty	Page 9
8. Storage of the Batteries	Page 9
9. Other The Chemical Reaction	Page 9
10. Note	Page 9



1 Scope

This specification is applying to describe the related Battery product in this Specification and the Battery/cell supplied by PLS Battery Co., Ltd only.

2 Model:21700-4000mah

3 Cell Specification

No.	Items	Specifications		Remark
1	Nominal Capacity	4000mAh		0.2C Standard discharge
2	Minimum Capacity	3950mAh		
3	Nominal Voltage	3.7V		Mean Operation Voltage
4	Delivery voltage	3.7~3.9V		Within 10 days from Factory
5	Charge Voltage	4.2V±0.03V		By standard charge method
6	Standard charging method	0.2C constant current,4.2V constant voltage charge to 4.2V,continue charging till current decline to ≤0.01C		About 5h (Ref)
7	Charge current	0.2C	800mA	Standard charge, charge time about 6h(Ref)
		1C	4000mA	Rapid Charge, charge time about: 3h(Ref)
8	Weight	About 65g		
9	Cell Internal Impedance	≤20mΩ		Internal resistance measured at AC 1KHz after 50% charge
10	Maximum charge current	1C	4000mA	For continuous charging mod
11	Maximum discharge current	3C	12000mA	For continuous discharge mod, Initial discharge capacity in the standard of discharge capacity of more than 80%
12	Operation Temperature and relative humidity Range	Charge	0~45°C 60±25%R.H.	Charge at a very low temperature such as blew 0°C,will be get a lower capacity and reduce cycle life of the battery
		Discharge	-20~60°C 60±25%R.H.	
13	Storage temperature for a long time	-20~25°C 60±25%R.H.		Do not storage exceed half year. Must charge once when storage for half year. must charge the battery which with protect circuit when storage for three months.



4 Battery/Cell performance test Criteria

4.1 Appearance inspection by visual

There shall be no such defect as rust, leakage, which may adversely affect commercial value of battery.

4.2 Environmental test condition

Unless otherwise specified, all test stated in this product specification are conduct at below test condition

Temperature: 20°C~25°C

Relative Humidity:60%±25% R.H.

4.3 Cell Electrical characteristics

No	Items	Test Method and Condition	Criteria	
1	Rated Capacity at 0.2C(Min.)	After standard charge, the capacity shall be measured on 0.2C discharge till the voltage discharge to 3.0V	≥3950mAh	≥100%
	Rated Capacity at 0.5C(Min.)	After standard charge, the capacity shall be measured on 0.5C discharge till the voltage discharge to 3.0V	≥3851mAh	≥97.5%
	Rated Capacity at 1C(Min.)	After standard charge, the capacity shall be measured on 1C discharge till the voltage discharge to 3.0V	≥3792mAh	≥96%
2	Cycle Life	Charging and discharging battery as blew conditions 0.2C standard charge to 4.2V end-off 0.2C standard discharge to 3.0V cut-off Continuous charge and discharge for 500 cycles, the capacity will be measure after the500 th cycle	≥70% of initial capacity	
3	Capacity retention	The battery to be charge in accordance with standard charge condition at 20~25°C, then storage the battery at an ambient temperature 20~25°C for 28 days. Measure the capacity after 30 days with 0.2C at 20~25°C as retention capacity	Retention capacity ≥85%	
4	Temperature Dependence of discharge capacity	Cells shall be charged per 3.3.1 and discharged @0.2 C ₅ A to 3.0 volts. Except to be discharged at temperatures per Table 3. Cells shall be stored for 3 hours at the test temperature prior to discharging and then shall be discharged at the test temperature. The capacity of a cell at each temperature shall be compared to the capacity achieved at 23 °C and the percentage shall be calculated.	Each cell shall meet or exceed the requirements of Table 3	



Table 3

Discharge Temperature	-20°C	-10°C	0°C	23°C	60°C
Discharge Capacity (0.2 C ₅ A)	40%	50%	80%	100%	95%

4.4 Mechanical characteristics

No	Items	Test Method and Condition	Criteria
1	Free fall test	The battery to be fully charged in accordance with standard charge condition, then drop the battery three times from a height of 1,0 m onto a concrete floor. The batteries are dropped so as to obtain impacts in random orientations.	No Fire,
2	Vibration test	After standard charging, fixed the cell to vibration table and subjected to vibration cycling that the frequency is to be varied at the rate of 1Hz per minute between 10Hz and 55Hz, the excursion of the vibration is 1.6mm. The cell shall be vibrated for 30 minutes per axis of XYZ axes.	No explosion ,No leakage, No fire



4.5 Safety performance

No	Items	Test Method and Condition	Criteria
1	Thermal exposure test	Each fully charged cell, stabilized at room temperature, is placed in a circulating air-convection oven. The oven temperature is raised at a rate of 5 °C/min ± 2 °C/min to a temperature of 130 °C ± 2 °C. The cell remains at this temperature for 10 min before the test is discontinued.	No explosion, No fire
3.	Short test	The fully charged battery is to be short-circuited by connecting the positive and negative terminals of the battery with resistance load not exceed 100m Ω .Tests are to be conducted at room temperature 20~25°C.	No explosion, No fire The Temperature of the Battery surface not exceeded than 150°C
4	Short test	The fully charged battery is to be short-circuited by connecting the positive and negative terminals of the battery with resistance load not exceed 100m Ω .Tests are to be conducted at room temperature about 60-65°C	No explosion, No fire The Temperature of the Battery surface not exceeded than 150°C
5	Forced discharge test	A discharged cell is subjected to a reverse charge at 1c for 90 min.	No explosion, No fire
6	Over charge test	After standard charge, continue to charge with a constant voltage 10V per a cell, holding 8h.	No explosion, No fire



5 Cell initial Dimensions

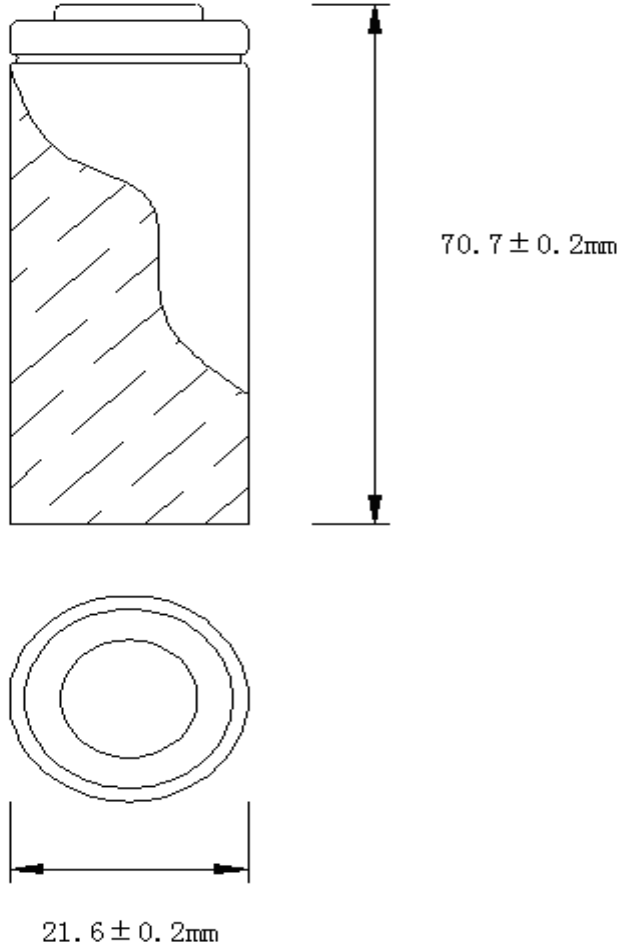

NO	Items	Units: mm
1	diameter (D)	21.6 ± 0.2
3	Height (H)	70.7 ± 0.2

Draw	Checked	Approved



6 CAUTIONS IN USE

To ensure proper use of the battery please read the manual carefully before using it.

. Handling

- Do not expose to, dispose of the battery in fire.
- Do not put the battery in a charger or equipment with wrong terminals connected.
- Avoid shorting the battery
- Avoid excessive physical shock or vibration.
- Do not disassemble or deform the battery.
- Do not immerse in water.
- Do not use the battery mixed with other different make, type, or model batteries.
- Keep out of the reach of children.

. charge and discharge. Battery must be charged in appropriate charger only.

- Never use a modified or damaged charger.
- Do not leave battery in charger over 24 hours.

. storage: Store the battery in a cool, dry and well-ventilated area.

. disposal

- Regulations vary for different countries. Dispose of in accordance with local regulations.

7 Period of Warranty

The period of warranty is one year from the date of shipment. PLS guarantees to give a replacement in case of cells with defects proven due to manufacturing process instead of the customer abuse and misuse.

8 Storage of the Batteries

The batteries should be stored at room temperature, charged to about 30% to 50% of capacity.

We recommend that batteries be charged about once per half a year to prevent over discharge.

9 Other The Chemical Reaction

Because batteries utilize a chemical reaction, battery performance will deteriorate over time even if stored for a long period of time without being used. In addition, if the various usage conditions such as charge, discharge, ambient temperature, etc. are not maintained within the specified ranges the life expectancy of the battery may be shortened or the device in which the battery is used may be damaged by electrolyte leakage. If the batteries cannot maintain a charge for long periods of time, even when they are charged correctly, this may indicate it is time to change the battery.

10 Note

Any other items which are not covered in this specification shall be agreed by both parties.